



INDUSTRIAL SOLUTIONS

FICOBA (Recinto Ferial Gipuzkoa)  
AVDA. IPARRALDE, 43 - ROOM 3  
20302 IRUN-GIPUZKOA (SPAIN)

☎ 00 34 646 211965

✉ RCC@RCCINDUSTRIAL.COM

📦 RCCINDUSTRIAL

WWW.RCCINDUSTRIAL.COM

LINEAR ACTUATOR  
推桿馬達

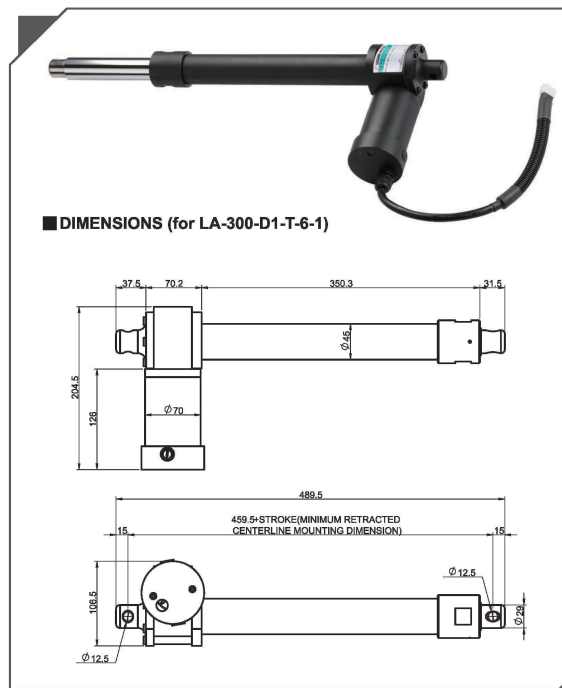
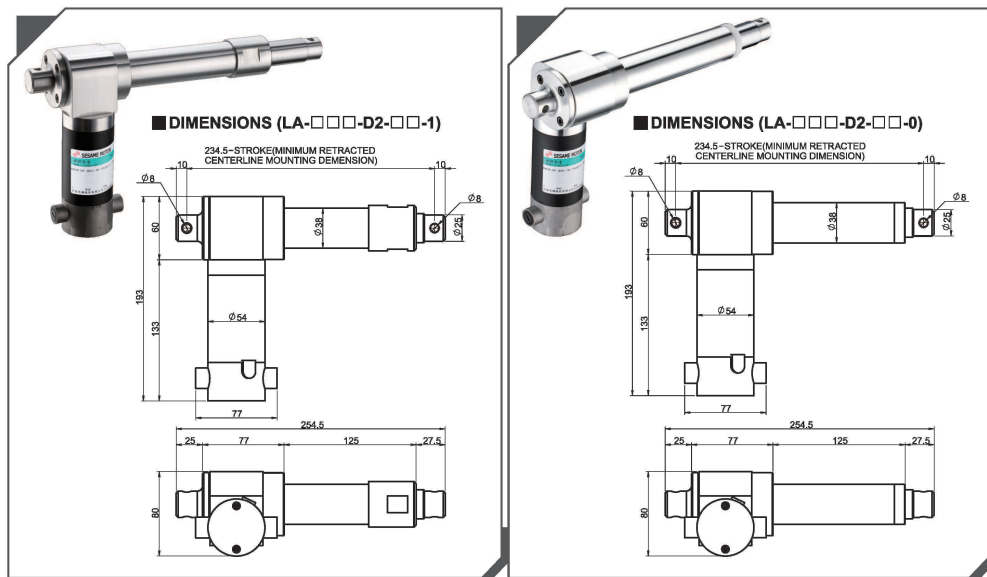

● 特性: FEATURES:

- 操作便利 Application Friendly
- 安裝簡單 Easy Install
- 低噪音 Low-Noise
- 高剛性/高強度 High stiffness / High strength
- 速度穩定 Steady speed

● 應用: APPLICATION:

- 農耕機 Operational convenience farming machines
- 排煙設備 Exhaust equipment
- 自動門 Automatic doors
- 自動化設備 Automation equipment
- 太陽能板日光追蹤自動轉向 Automatic tracking for Solar Panels
- 自動升降輪椅 Automatic wheelchair lifting
- 電動升降病床 Electric lift bed
- 吊重設備 Lifting equipment
- 復健器材 Rehabilitation equipment

MODEL	Load (Static) Kgf	Hanging Load (dynamic) kgf	Stroke (mm)	Gear Ratio	Stroke Speed (mm/s)	Duty Cycle	Stall Protection	Voltage (V)	Weight (Kg)	Option
LA-050-D2-□-□-0	50~250	25~125	50	10/20/30	15/10/5	10%	Yes	DC24	2.7	-
LA-100-D2-□-□-0	50~250	20~125	100	10/20/30	15/10/5	10%	Yes	DC24	3	-
LA-150-D2-□-□-0	50~250	20~100	150	10/20/30	15/10/5	10%	Yes	DC24	3.3	-
LA-200-D2-□-□-0	50~250	15~80	200	10/20/30	15/10/5	10%	Yes	DC24	3.5	-
LA-250-D2-□-□-0	50~250	15~80	250	10/20/30	15/10/5	10%	Yes	DC24	3.8	-
LA-300-D1-T-6-1	1000	250~350	300	32	6	10%	Yes	DC12	9	IP66

■ DIMENSIONS (for LA-300-D1-T-6-1)

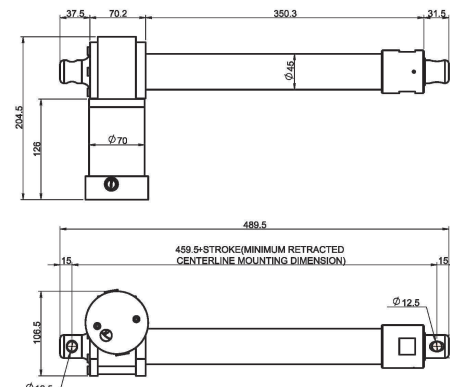

輸入電壓/電流 INPUT VOLT/CURRENT	12V DC / 10.5A
最大安培 MAX. CURRENT LIMIT	25A
功率 OUTPUT POWER	60W
保護等級 PROTECTION CLASS	IP 66
重量 WEIGHT	9 kg
行程時間 STROKE SPEED	6mm/sec
減速比 GEAR RATIO	1/32
總行程 STROKE	300 mm
運轉週期 DUTY CYCLE	10%
負重/吊重 LOAD/HANGING LOAD	1000 kg / 250~350 kg

備註:

1. 可依客戶需求開發更改比數、行程以及其他規格。
2. 本公司若有設計或規格變更時，恕不另行通知。

NOTES:

1. Gear ratio, stroke length and other specifications can be made to fit customer's requirements.
2. Design and specifications subject to change without advance notice.

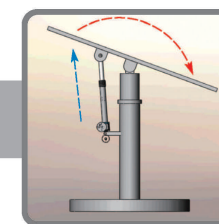
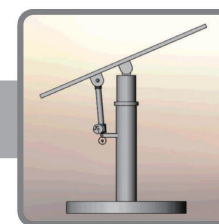

◀ 適用於太陽能裝置設備上。  
Applied in Photovoltaic Installations.

● 應用範圍 APPLICATIONS

- 各類農用機械。 VARIOUS AGRICULTURAL MACHINERY.
- 各類需負重舉起之設備機具：如醫療器材及車載裝置。 VARIOUS EQUIPMENT THAT NEED TO LIFT UP A LOAD: SUCH AS MEDICAL INSTRUMENTS AND VEHICULAR INSTALLATIONS.
- 各類吊重結構設備：如輕型之吊車裝置。 VARIOUS CONSTRUCTIONS USED FOR HANGING A LOAD: SUCH AS LIGHTWEIGHT HOISTING MACHINES.
- 適合應用於不同惡劣環境之設備：防水、防塵。 TO BE USED UNDER UNDESIRABLE WEATHER CONDITIONS: WATERPROOF, DUSTPROOF.

GENERAL PURPOSE MOTOR  
內五型馬達  
SPEED CONTROLLED MOTOR  
變速馬達  
CONTROL LINE  
控制線  
BRAKE MOTOR  
煞車馬達  
CUT-OFF BRAKE MOTOR  
離合煞車馬達  
TORQUE MOTOR  
轉矩馬達  
SPEED REDUCER  
減速機  
COMPONENTS  
零件類  
LINEAR ACTUATOR  
推桿馬達